

F50 Series – Rugged Trackball Module, USB, 3 Switches, Green HALO Light Feature

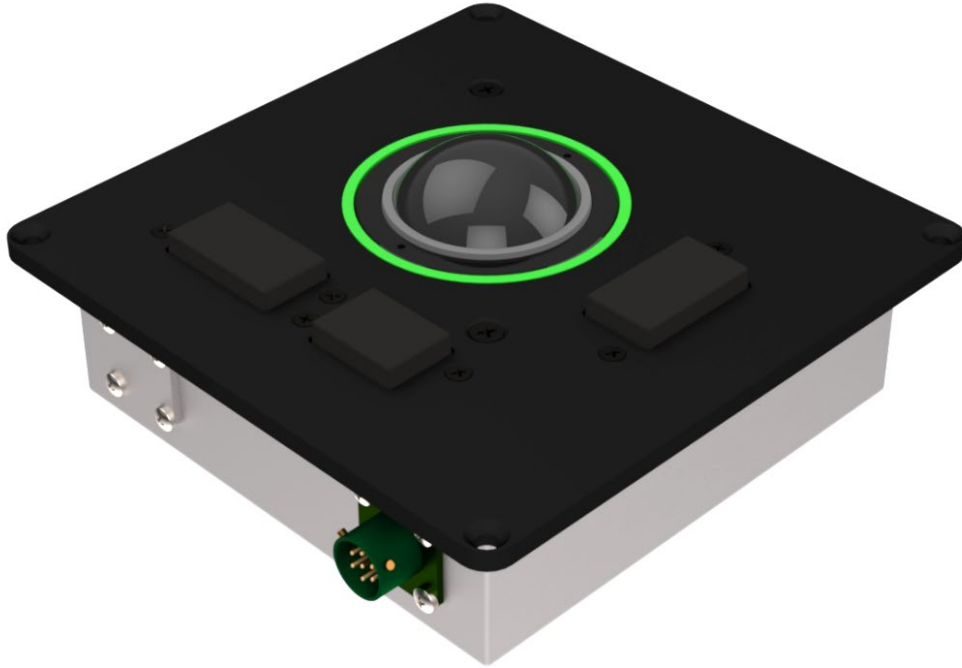

Figure 1: CCL F50-553160-A043 Trackball module

1 SPECIFICATIONS

1.1 MECHANICAL		
1.1.1	Weight	1100 grams (+/- 10%)
1.1.2	Ball size	Ø50.8 mm (2")
1.1.3	Ball material	Epoxy resin
1.1.4	Ball tracking force	30-80 grams
1.1.5	Ball load	200N for 2 minutes
1.1.6	Resolvable ball speed	30 inches per second
1.1.7	Top plate material/finish	Brushed Aluminium/ Black anodised
1.1.8	EMC can material/finish	Aluminium/Surtec 650
1.1.9	Ball retention style/colour	Removable aluminium threaded locking ring, black
1.1.10	Ball sealing material	PTFE composite
1.1.11	HALO Illumination Colours	Green
1.1.12	Operating position	Horizontal to 60°
1.1.13	Tracking engine	Dual channel photo-interrupters
1.1.14	Switch actuation force	100 – 120 grams
1.1.15	Switch travel	3mm +/- 0.5mm
1.1.16	Switch lifetime	1,000,000 cycles
1.1.17	Mechanical lifetime	1 million ball revolutions
1.1.18	MTBF	Ground benign 25°C = 348,000 hours
1.1.19	Trackball Revision	001

1.2 ELECTRICAL		
1.2.1	Protocol/output	USB
1.2.2	Supply voltage	4.4 to 5.25V D.C.
1.2.3	Supply current	90mA typical, 100mA Maximum
1.2.4	Resolution	846 counts per ball revolution – linear tracking mode
1.2.5	Output connector	Amphenol 62GB-12E10-07PN or equivalent (7-way circular connector)
1.2.6	Mating output connector	Compatible 7-way socket e.g., Amphenol part 62GB-56T10-07 SN
1.2.7	Integrated switches	3 switches: Left, Middle, and Right (other options available)
1.2.8	PCB protection	Silicone conformal coating

1.3 ENVIRONMENTAL		
1.3.1	Operating LOW temperature	RTCA DO 160F, Section 4.5.2, 2 hours @ -45°C (Category B2)
1.3.2	Operating High temperature	RTCA DO 160F, Section 4.5.4, 2 hours @ +70°C (Category B2)
1.3.3	Ground Survival LOW temperature	RTCA DO 160F, Section 4.5.1, 3 hours @ -55°C (Category B2)
1.3.4	Ground Survival HIGH temperature	RTCA DO 160F, Section 4.5.3, 3 hours @ +85°C (Category B2)
1.3.5	Altitude	RTCA DO 160F, Section 4.6.1, 2 hours @ 25,000ft (37.6KPa) (Category B2)
1.3.6	Rapid Decompression	MIL-STD-810F, Method 500.4, Procedure III, 40000ft, 15secs, dwell = 10mins.
1.3.7	LOW temperature power on	RTCA DO 160F, Section 5, -45°C (Category B)
1.3.8	Temperature variation	RTCA DO 160F, Section 5, -45°C to +70°C @ 5°C/min, 2 cycles (Category B)
1.3.9	Humidity	RTCA DO 160F, Section 6, 95% @ 65°C, non-condensing (Category B - Severe)
1.3.10	Ingress Protection Rating	IPX5 (IEC 60529)
1.3.11	Dust	MIL-STD-810F, Method 510.4, Procedure I
1.3.12	Sand	MIL-STD-810F, Method 510.4, Procedure II
1.3.13	Salt Fog	MIL-STD-810F, Method 509.4
1.3.14	Vibration (Minimum Integrity Test)	MIL-STD-810G, Method 514.5, Procedure I, Category 24, All 3 axis, duration = 1 hour per axis, 7.7g RMS, 20 to 2000Hz
1.3.15	Functional Shock	MIL-STD-810G, Method 516.5, Procedure I, 40g, 15-23ms duration, 3 shocks in +/-directions, operating,
1.3.16	Crash Hazard	MIL-STD-810G, Method 516.5, Procedure V, 75g, 15-23ms duration, 2 shocks in +/-directions ,

1.4 ELECTROMAGNETIC COMPATIBILITY		
1.4.1	EMC	MIL-STD-461E tests as detailed: CE101, 30Hz to 10kHz, Navy and Army Aircraft (fig CE101-4) CE102, 100kHz to 10MHz (fig CE102-1) RE101, 30Hz to 100kHz, Navy applications (fig RE101-2) RE102, 10kHz to 18GHz, Helicopter applications (fig RE102-3) RS101, 30Hz to 100kHz, Navy application (fig RS101-1) RS103, 2MHz to 18GHz, 60V/m CS101, 30Hz to 150kHz (fig CS101-1) CS114, 10kHz to 200MHz, Curve 5 CS115, All applications (fig CS115-1) CS116, 10kHz to 100MHz, Air force Applications - I _{max} = 5amps (fig CS116-2)
1.4.2	ESD	EN 61000-4-2 Level 4 (8kV contact , 15kV air)
1.4.3	EFT	EN 61000-4-4 Level 4 (4kV)

1.5 OPERATING SYSTEM COMPATIBILITY		
1.5.1	USB	Windows OS, Linux
		Fully compliant with USB 2.0 framework (chapter 9) & HID specifications

2 CONNECTION DETAILS

Connection is made to the F50 trackball by means of a single circular connector. Tables 1 and 2 highlight the connection details.

2.1 Output Connector

Description	7-way circular connector with bayonet latching features
Manufacturer	Amphenol (or equivalent)
Manufacturer Part Number:	62GB-12E10-07PN (or equivalent)
Mating Connector:	Compatible 7 way socket e.g. 62GB-56T10-07SN, 62GB-16F10-07SN or equivalent (7 way circular socket)

Table 1: Output Connector Details

PIN	USB OUTPUT
A	D-
B	D+
C	Do not connect
D	Do not connect
E	Do not connect
F	GND (0V)
G	5V D.C
SHELL	EARTH

Table 2: Output Connector Pinout

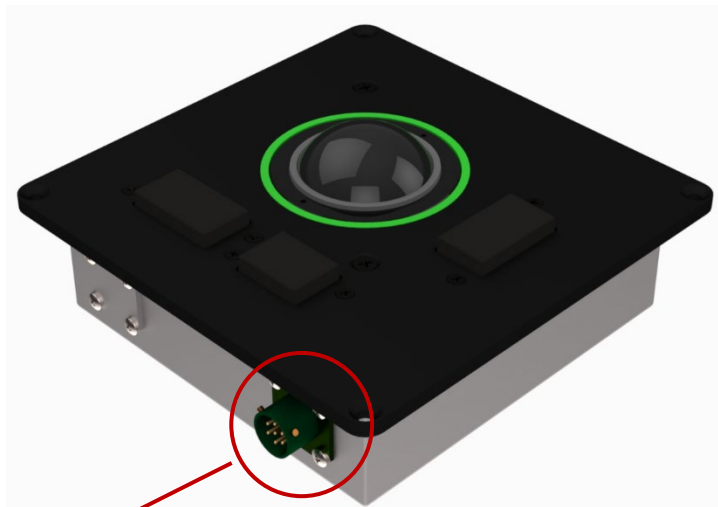
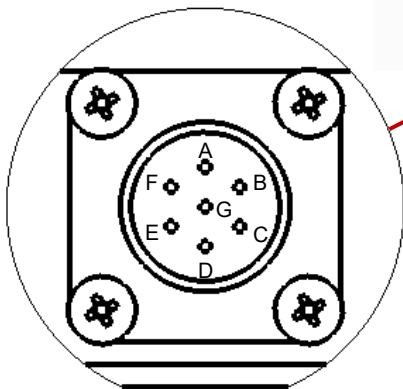

Figure 2: Connector Details



Output Connector

3 TRACKBALL CONFIGURATION

3.1 Switch Arrangement

Figure 3 below highlights the switch arrangement for the F50 trackball module.

Left Switch: The functionality corresponds to the left button on a standard mouse.

Middle Switch: The functionality corresponds to the middle button on a standard mouse.

Right Switch: The functionality corresponds to the right button on a standard mouse.

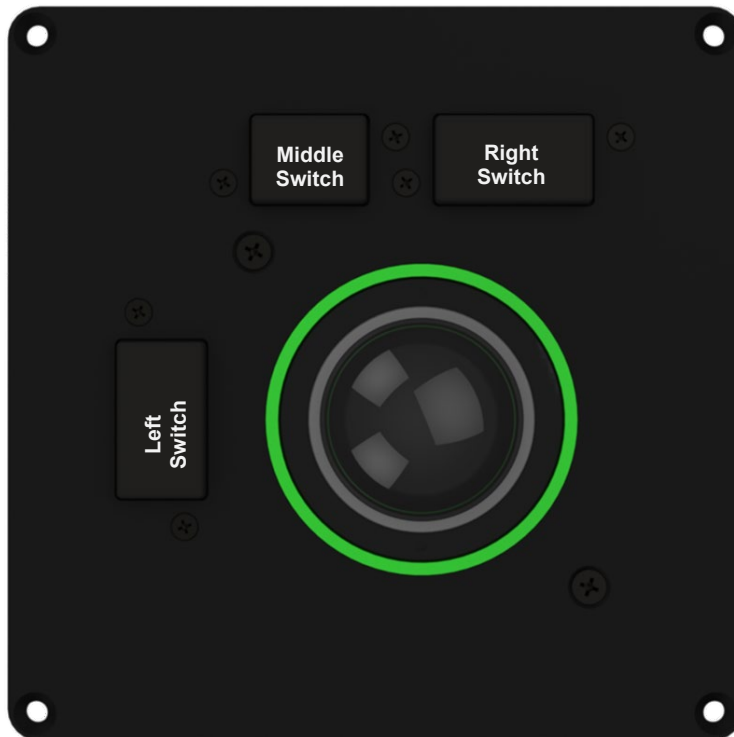

Figure 3: Switch Arrangement

3.2 Orientation

The F50 trackball module is configured to operate with the connector orientated on the left-hand side (when viewed from the top of the module). Please note that alternative orientations are available upon request. Please contact your local sales office for more information.

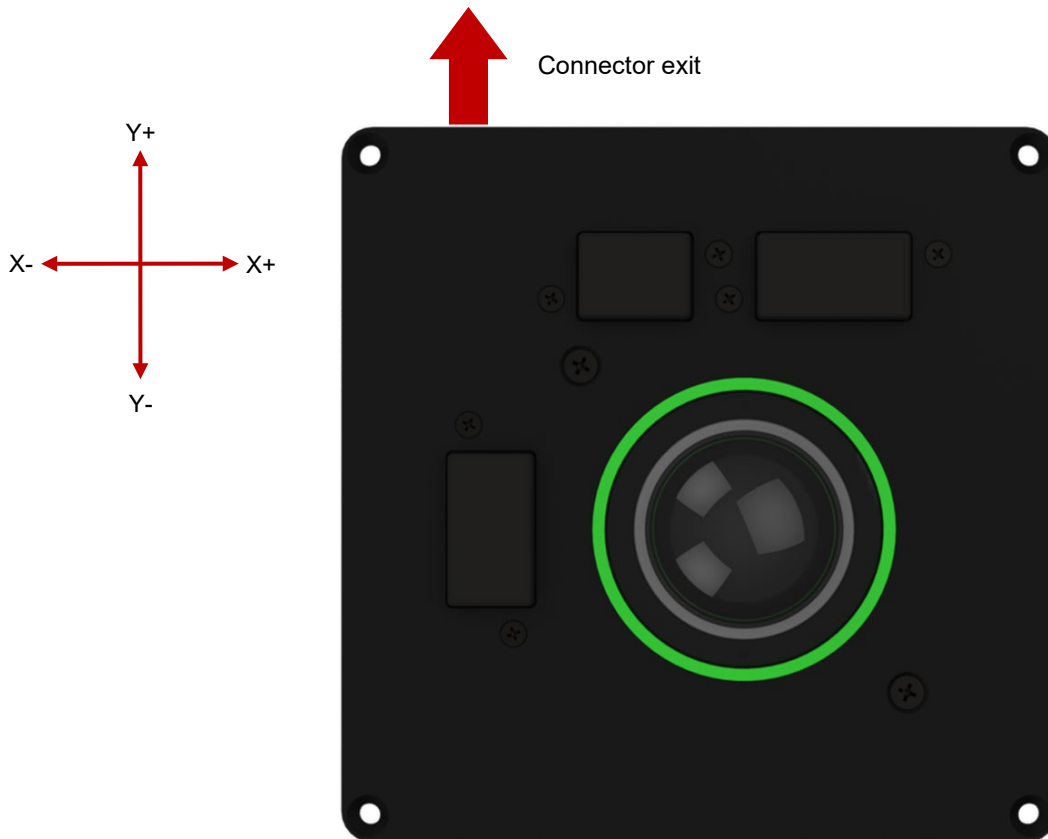

Figure 4: Mounting Orientation

3.3 Tracking Mode - Ballistic Tracking Feature

The F50 trackball module utilizes an intuitive ballistic tracking algorithm that provides increased cursor resolution with fast ball movements whilst retaining the native resolution (846 counts per revolution) at slow tracking speeds. This feature enables more efficient tracking on systems with large screens or monitors and at the same time ensures tracking accuracy is maintained at slow speeds.

The algorithm applies a gain which is directly related to the velocity of the ball and results in larger displacements of the cursor at faster ball speeds.

3.4 Anti-Vibration Technology

The F50 Series trackball incorporates the latest Cursor Controls Ltd patented anti-vibration technology. The anti-vibration technology ensures that only intended ball movements are transmitted to the host system (i.e. when the user's hand is in contact with the surface of the ball). This feature eliminates any unwanted cursor motion resulting from ball movement caused by external shocks or vibrations. For additional information regarding this technology please refer to application note AN0037.

3.4.1 Anti-Vibration Initialisation

At the start of each power cycle the anti-vibration feature will default to an inactive state until it detects the very first contact made by a finger/hand. This initial inactive state allows the feature to calibrate to the operating environment and distinguish when hand contact is made. Please note that prior to this initial finger/hand detection it is possible that any shock/vibration may cause unintended cursor movement on screen.

The anti-vibration feature has been designed to recognise a touch at a height of approximately 1mm from the ball surface to ensure that the ball can still be operated with a gloved hand (e.g. NBC and military flight gloves).

3.4.2 Activation Levels

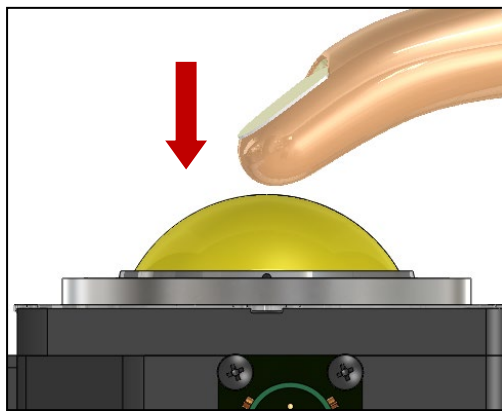

Ball motion will be transmitted when the finger is between 0 to 1mm away from the ball surface

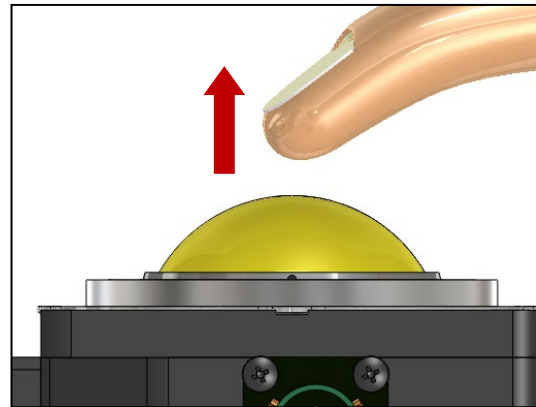

Ball motion will be suppressed when the finger is over 2mm away from the ball surface

Figure 5: Anti-vibration Operation

3.5 HALO Light Feature

The F50 Series HALO trackball module provides all the features of the standard F50 trackball module with the inclusion of an illuminated ring surrounding the ball. The light ring provides an excellent means of locating the trackball in low level light environments and also serves as an aesthetic feature to compliment other illuminated components incorporated within a user interface panel. Figures 6 and 7 below show the HALO feature in its powered and non-powered state.

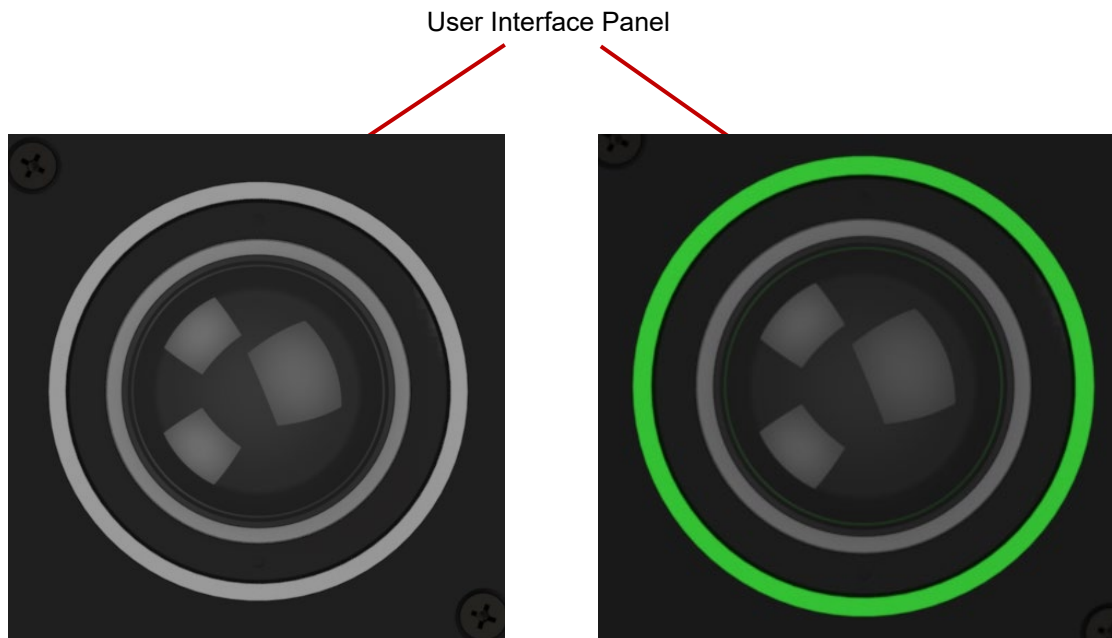
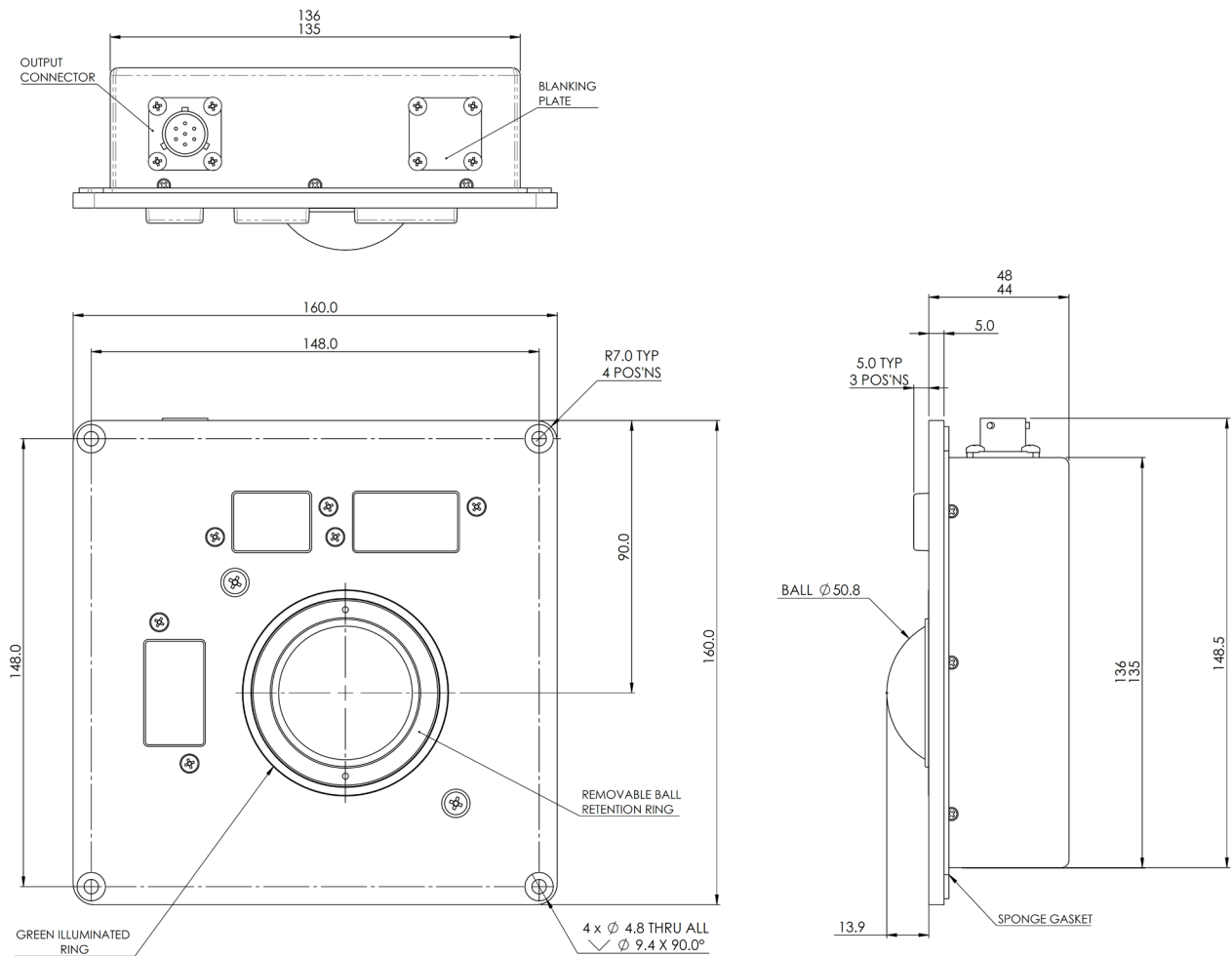

Figure 6: Trackball light ring – non-illuminated

Figure 7: Trackball light ring – Illuminated

4 OUTLINE DRAWING



Dimensional drawing specifies factory default orientation.

All dimensions are in mm unless otherwise stated.

Tolerances +/- 0.2mm unless otherwise stated

Please note that an IGES model is available on request. Please contact your local sales office for more information.

5 RECOMMENDED PANEL CUT-OUT

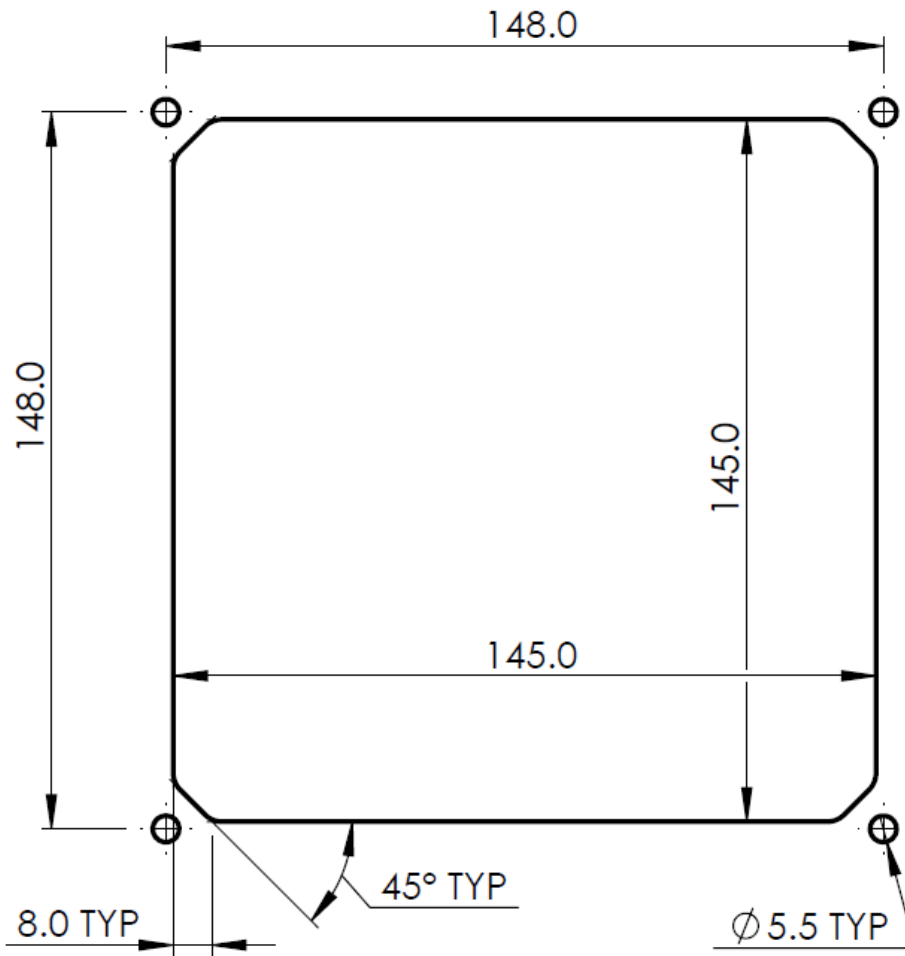

Figure 8: Recommended Panel Cut-out

6 MANUFACTURE

6.1 Environmental Impact Requirements

The device shall not contain any toxic materials other than those necessary for soldering purposes.

6.2 ESD Protection

All CCL products shall be manufactured in an ESD safe environment. ESD precautions shall be observed through the production and packing process.

6.3 Workmanship

The trackball device has been designed and produced in accordance with IPC-A-610, Class 2. All Printed Circuit Boards and all soldering are conformal coated to IPC standards.

7 PACKAGING AND SHIPPING REQUIREMENTS

7.1 CCL Trackball Identification

Each trackball shall be marked with a label detailing the following information:

1. Name of manufacturer
2. Cursor Controls part number
3. Cursor Controls serial number(Human Readable)
4. Cursor Controls serial number(Machine Readable)
5. Cursor Controls date code

Label format

Label Size: 25.4 x 9.53 mm

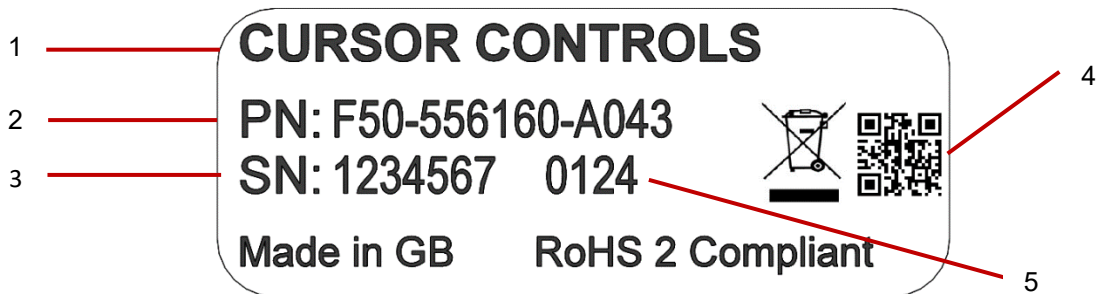

Figure 9: Serial No. Details

The label shall be covered by a clear, protective over-laminate measuring 50mm x 20 mm and this shall overlap the label on all sides.

7.2 ESD Labelling

The trackball module and its packaging shall be clearly labelled stating that the product must be handled in an ESD safe manner. ESD warning labels shall comply with MIL-STD-129



Figure 10: ESD Label Details

7.3 Label Placement

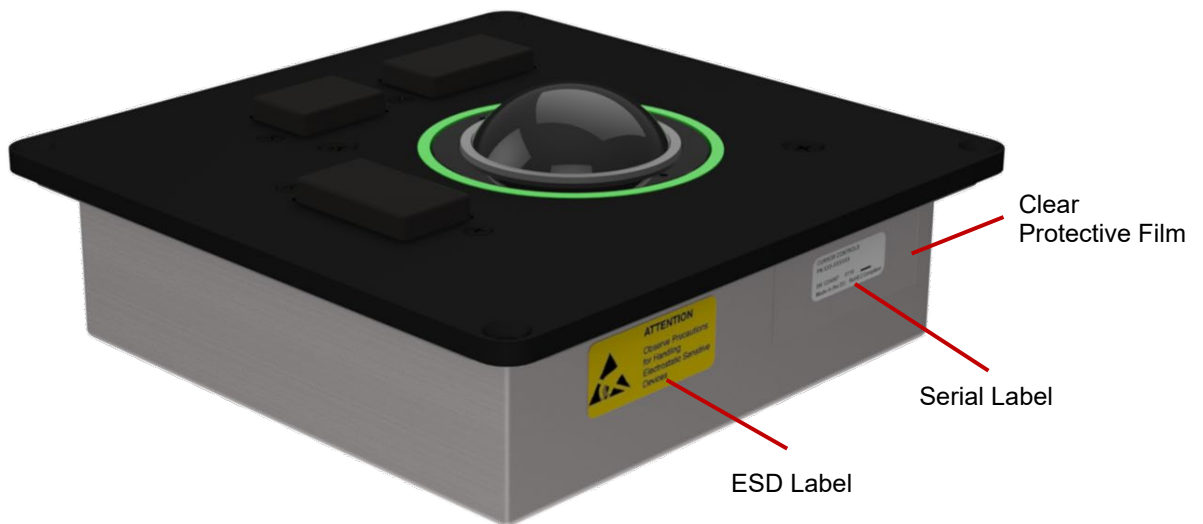

Figure 11: Label Placement

7.4 Packaging

Each box, in which the trackballs are packaged, shall be marked with:

- Cursor Controls part number
- Cursor Controls revision
- Trackball quantity

Each trackball shall be packed in an ESD-protected package.

8 SUPPORT DOCUMENTS

The following documents provide support information for the F50 Series trackball and are available upon request from your local sales office.

NOTE: PLEASE READ THE SUPPORT DOCUMENTS CAREFULLY BEFORE INSTALLING THE TRACKBALL.

DOCUMENT NUMBER	DESCRIPTION
AN0035	Application note: Servicing Guide
AN0036	Application note: Trackball Installation
AN0037	Application note: Capacitive Anti-Vibration Guide

Table 3: Support Documents

9 DOCUMENT REVISION STATUS

ISSUE	DATE	AUTHOR	REMARKS
01	24/01/24	H.W.	Initial release – NP1433

Whilst the information provided herein is to the best of our knowledge true and accurate, it should be used for guidance only and may be subject to change. You are therefore advised to ensure all information provided herein is current and up to date and suitable for your application. Use of Cursor Controls Ltd products in life support/critical systems is only permitted with prior written consent of the Company.

All information contained herein should be regarded as confidential and is supplied subject to Cursor Controls Ltd Terms and Conditions – a copy of which is available on request or can be found at www.cursorcontrols.com/terms-conditions